

Symbols

- Stone screw
- Levelling screw
- ⊗ Connection of cooling water
- ⊠ Connection - waste water
- ⊙ Connection of compressed air
- ▲ Connection of heating gas

- 4 Stone screws M 20 x 250 DIN 529
- 4 Spring washers A 20 DIN 127
- 4 Hexagonal nuts M 20 DIN 934

Connection load = 18kVA

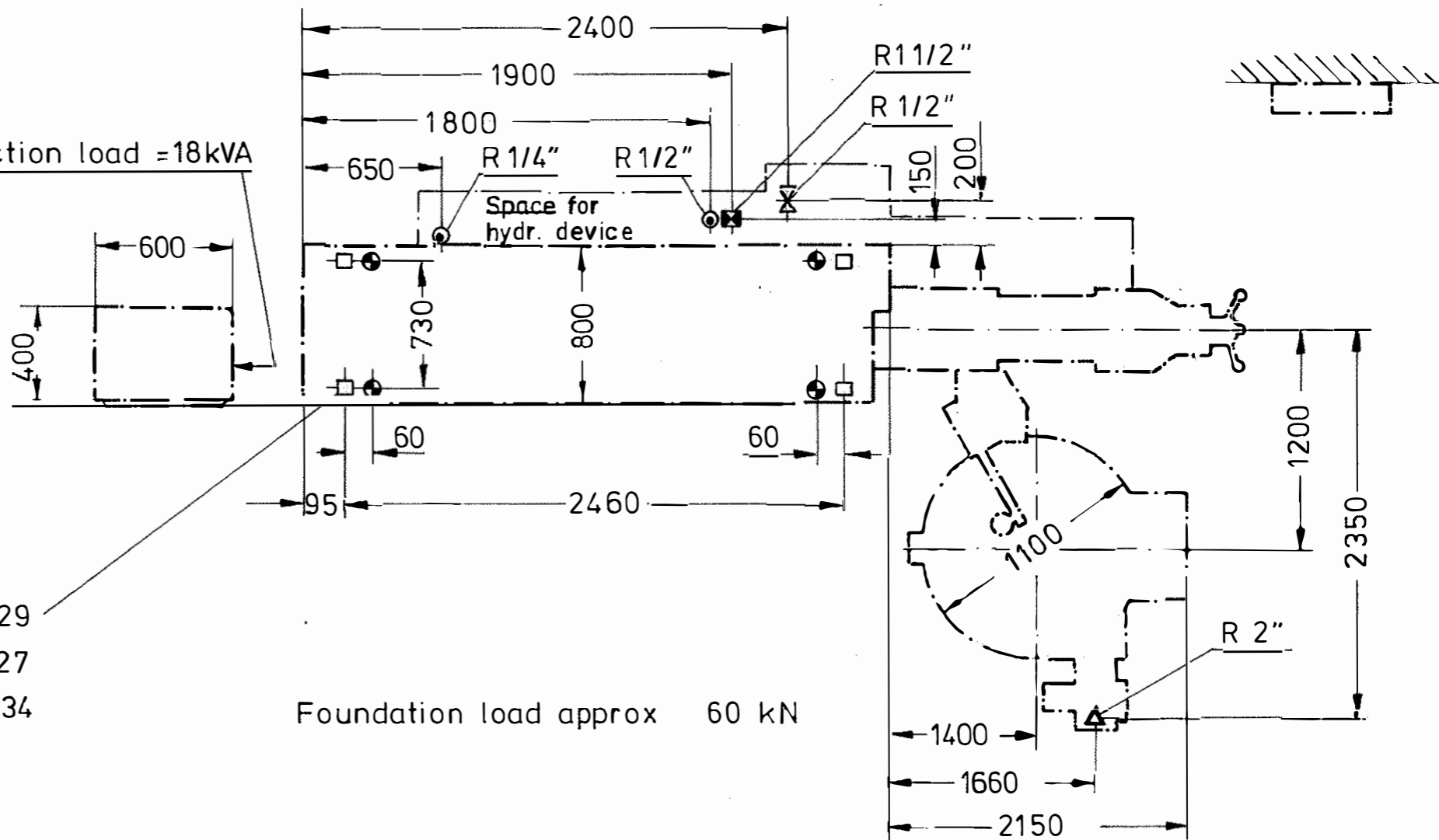

Foundation load approx 60 kN