

2. Maintenance and Servicing

2.1 Maintenance Plan

2.1.1 Maintenance Schedule

2.2 Change of Hydraulic Fluid

2.3 Reservoir and Filter Cleaning

2.4 Temperature of Hydraulic Fluid

2.5 Checking of Filling Pressure of Accumulator

2.6 Maintenance of Electrical Equipment

2.7 Directions for Lubrication

2.7.1 Lubrication Chart

2.7.2 Lubricants and Hydraulic Fluids

2.8 Required quantities of Oil and Nitrogen

2.9 Instructions to the Hydraulic Pump

2.1 Maintenance Plan

Operational safety and long life of the machine largely depend on a regular servicing by qualified personnel.

Hydraulic - Pressure accumulator

Checking of nitrogen pressure.

First check after one week. After that over the period of the first two months the checks are to be carried out every two weeks and thereafter every three months. Top up with nitrogen at low filling pressure.

Hydraulic Fluid

First change after 500 operating hours, then every 2000 operating hours.

Hydraulic Tank

Cleaning after every fluid change.

Press Filter

Attention: For the cleaning of the hydraulic fluid the press filter includes a paper filter insert. After approx. 8 operating hours it must be changed by the delivered operating filter insert.

Suction Filter

Cleaning once a year at least.

Lubrication

According to lubrication directions and lubrication diagram.

Electric Control and Electric Motors

Checks and thorough cleaning once a year.

Cleaning of the Machine

Daily cleaning, once a week a through cleaning is required paying special attention to the electric limit switches.

2.2 Change of Hydraulic Fluid

The first change of the hydraulic oil is required after 500 operating hours. After filtration the oil can be re-used. Further oil fillings are required at an interval of 2000 operating hours. Losses must always be replaced by new oil of the same type.

The position of the inlet and of the drain plug can be seen on the illustration of paragraph 3. When filling the tank the oil level should reach up to the top of the inspection glass as the hydraulic oil distributes into the pipes and cylinders of the machine when the machine starts.

Attention: For the cleaning of the hydraulic fluid the press filter includes a paper filter insert. After approx. 8 operating hours it must be changed by the delivered operating filter insert.

2.3 Cleaning of Tank and Filter

With every oil change the tank and the suction filter must be cleaned, too. No cotton waste or other fluffy material are to be used.

The suction filter is screwed on to the suction pipe of the pump and is easily accessible after removal of the tank lid. As the resistance to suction influences the life of the pump considerably special care must be taken to ensure unhindered suction efficiency.

The filter insert of the pressure filter is removed by unscrewing of the filter bell. Please take care of the seal ring which should not be forgotten during the assembly.

If the high pressure filter is contaminated above the permissible level the signal lamp on the switch panel lights up. The exchange of the filter insert is now an absolute necessity.

2.4 Temperature of Hydraulic Fluid

During continuous operation it should not rise above 50 ° C. We recommend to check the temperature by means of the inbuilt thermometer. The working pressure of the hydraulic fluid can be held on the adjusted level by the flow recuperator with thermostatic regulated cooling water supply.

The minimum oil temperature during commissioning should not fall below 15 ° C. For lower temperatures we recommend pre-heating of the oil to at least 15 ° C (oil pre-heating facility).

2.5 Checking of the Filling Pressure of the a Accumulator

For measuring and refilling of the accumulator use the filling device. Before these actions the oil in the accumulator must be released. This is carried out simply by switching off the machine. The automatic pressure discharge allows the back-flow of the oil in the tank. Check with manometer if accumulator is pressureless. Information concerning the measuring of the filling pressure and the refilling you will find in the accumulator operating instructions. The level of the filling pressures can be obtained from the schedule in section 3.

2.6 Maintenance of the Electrical Equipment

The relays and limit switches contain silver contacts. These should never be filed or rubbed with emery paper. Black discolouration of these contacts during the operation by silver deposit has no influence on their function.

It is paramount to keep always the outer parts of the limit switches clean. Foreign substances can draw back the function of these switches. Once a year, the complete electrical system should be cleaned thoroughly. We recommend to tighten all plugs and cable connections.

MAINTENANCE SCHEDULE

Daily	Weekly	Monthly	Yearly
Cleaning of machine	- Thorough cleaning especially limit switches	- Storage tank (bag type accumulator)	- Clean electrics
Check oil level	- Check hydraulic system for leakage	-	- tightening up of terminals and cable connections
Check oil temperature	- Storage tank (bag type accumulator) see maintenance	- Furnace heating see burner operational directions	- Hydraulic fluid see maintenance plan
Lubrication	- Pressure filter insert	-	- If required descaling of water system
Check pressure gauges	- Hydraulic fluid see maintenance plan		
Pressure filter see maintenance plan	- Molten bath temperature to be measured by manual pyrometer and to be compared with furnace regulator		
Check lubricants and top up if necessary			

PRECH

Instructions for lubrication

In order to guarantee a high level of efficiency and a long life of our high performance automatic diecasting machines, it is absolutely necessary that they are carefully lubricated with the most suitable lubricants. Unqualified selection of lubricants can cause operating failure, which can be extremely costly if the machine breaks down. Therefore we recommend the use of lubricants as shown in the table.

If the machine is fitted with a manual central lubricating mechanism, all lubrication points of the locking unit are centrally lubricated with the required amount of grease via built in nozzles. Only oil-type lubricants can be used in the central lubricating mechanism.

With automatic central lubrication, the lubrication impulse is adjusted at the impulse counter. Lubrication is being repeated every time the pre-selected shot number has been reached. Every time the machine is switched on, a lubricating impulse follows. The lubrication pump is switched off by a pressure switch, when the required oil pressure is achieved in the system. The central lubrication system works hydraulically and therefore has to be free from air. For ventilating purposes the highest couplings of the main pipes have to be opened and ventilated individually one after the other. The pump has to be activated several times until the oil comes out of the coupling bubble-free. Check outlet to every distributor.



The lubricating points at the sprue breaking platen, at the drive of the die height adjustment and at the injection traverse are being fed by the grease pump supplied.

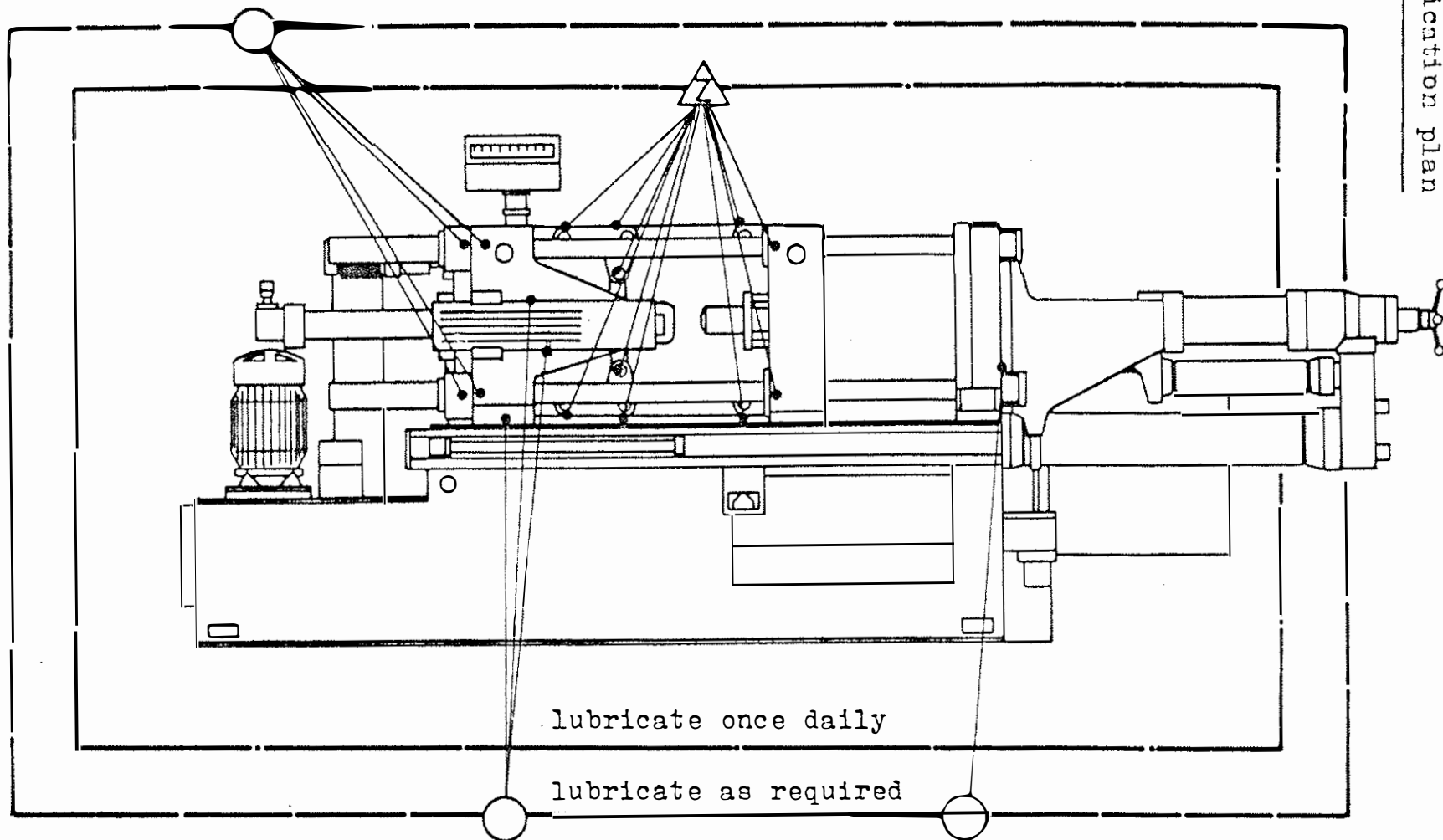

Note: We recommend to check the functioning of the central lubrication system once a week. A quick and simple method is to visually check each lubricating point for excess lubricant.





lubricate once daily

lubricate as required

The locations that are to be lubricated daily are to be lubricated before starting operations. For machines that are not fitted with the central lubricating system, the appropriate grease nipples  are also to be lubricated with grease . The central movement is to be lubricated as required.

-  - Grease
-  - Lubricating oil
-  - Central lubricating system

Manufacturer		BP	Mobil	Shell	Esso	Optimol	Klüber Lubrication	Aral	Houghton Hildesheim	IBS Fleischer	Wenzel & Weidmann	Brenntag		
Lubricating oil C-LP DIN 51517 T3 Viscosity 150 mm ² /s(cSt)/40°C		GR-XP 150 °(ISO)	Mobilgear 629	Omala Oil 150	Spartan EP 150	Ultra 5120	Lamora 150	Aral Degol TU 150						
Lubricating grease NLGI-Kl. 2 DIN 51804 +high pressure increase EP - additive		Energrease LS 2	Mobilux EP 2	Alvania EP 2	Beacon EP 2	Olista Longtime2	Unimoly GL 82	Aral -Fett HLP 2						
Lubricating grease Mg - machine DAM 63 - 500							Wolfrakote Top Paste							

Hydraulic oil H - LP 36 36cSt/50°C DIN 51525 high flash		Energol HLP46 (ISO)	Mobil D.T.E. 26	Tellus Oil 933	Nuto - H 54	Hydo 5045	Lamora HLP 46	Aral Vitam GF 36						
Hard inflammable hydraulic fluid HS - C Basis - Water - Glycol VDMA - Blatt 24 317		Olex SF-Co454	Hydrofluid HSC	WG Fluid C		Hydosafe W 5040		Aral Vitam HC 36	Houghto- safe 620	Pyrosafe 27	Ecubsol Hydrotherm 46 NF	Hydrolub 35		

Supplying firm's addresses:

Deutsche BP AG, 7000 Stuttgart 1 - Postfach 500
 Mobil Oil AG, 2000 Hamburg 1 Steinstrasse 5
 Deutsche Shell AG, 7000 Stuttgart 1 - Postfach 709
 Esso AG, 7000 Stuttgart 60 - Postfach 167
 Optimol - Ölwerke GmbH, 8000 München 80 Friedenstr. 7
 Klüber Lubrication KG, 8000 München 70 Geisenhausenerstr.7
 Aral AG, 7000 Stuttgart 60 - Postfach 169
 Houghton, 3200 Hildesheim Am Römerring 12-14
 IBS Fleischer, 7067 Plüderhausen Boschstr. 5
 Wenzel & Weidmann GmbH, 5180 Eschweiler - Postfach 1429
 Brenntag GmbH & Co, 4330 Mülheim (Ruhr) - Postfach 010320

Our customers have been using these products for years without any important wear and tear problem occurring.

The succession of the suppliers does not indicate the order of preference.

FRECH

Lubrication table

QUANTITIES OF HYDRAULIC FLUID AND NITROGEN

Machine Typ	Approximate Quantity of hydr. fluid to be ordered for start up	(1) Quantity of oil to be ordered for start up	(2) Quantity of nitrogen needet
DAW 5	130 ltrs/48 US gal. 40 British gal.	1 drum	1 bottle
DAW 10	120 ltrs/32 US gal. 27 British gal.	1 drum	1 bottle
DAW 20 DAW 20 E	130 ltrs/48 US gal. 40 British gal.	1 drum	1 bottle
DAW 40 DAM 40	300 ltrs/80 US gal. 75 British gal.	2 drums	1 bottle
DAW 63 DAM 63	340 ltrs/90 US gal. 75 British gal.	2 drums	1 bottle
DAK 63	270 ltrs/72 US gal. 60 British gal.	2 drums	1 bottle
DAW 125 DAM 125	520 ltrs/138 US gal. 114 British gal.	3 drums	2 bottles
DAK 125	500 ltrs/132 US gal. 110 British gal.	3 drums	2 bottles
DAW 200 DAM 200	500 ltrs/132 US gal. 110 British gal.	3 drums	2 bottles
DAK 200	500 ltrs/132 US gal. 110 British gal.	3 drums	2 bottles
DAW 200-A DAM 200-A	650 ltrs/172 US gal. 143 British gal.	4 drums	2 bottles
DAK 200h-A	650 ltrs/172 US gal. 143 British gal.	4 drums	2 bottles
DAW 315 DAM 315	540 ltrs/143 US gal. 119 British gal.	3 drums	3 bottles
DAK 315 h	620 ltrs/164 US gal. 137 British gal.	4 drums	3 bottles
DKG 800	980 ltrs/259 US gal.	5 drums	2 bottles

(1) drum with 200 ltrs; 55 US gallon contents.;
44 British gallons

(2) normal bottles 40 ltrs. with 140 at3

COMMISSIONING OF THE PUMP FOR HYDRAULIC HSC FLUIDS ACCORDING TO VDMA 24 317 (WATER-GLYCOL-SOLUTION)

In order to increase the service life of the pump the following points should be observed when commissioning the new pump:

1. Was the hydraulic filter cleaned?
2. Has the water-glycol altered in composition and contamination?

The hydraulic medium should be checked at regular intervals (this inspection is normally undertaken by fluid suppliers). If there is a contamination the hydraulic medium should be cleaned by means of a separate filter plant (this filter plant should only be used for water glycol).

As a result of using water-glycol in diecasting machines, the operator must conduct stringent tests on this medium. The higher density, greater intake of dirt and the poor air separating ability of water-glycol compared with mineral oil fluids lead to breakdowns of the machine or even to pump breakdown if there are minor irregularities in maintenance.

The temperature of the medium should be continually checked. The fluid temperature in the tank must not exceed 50 °C. Operating even for a short time above this temperature leads to steam bubbles and to the failure of equipment.